

- Submersible Pumps
- Trailer-Mounted Pumps
- Skid-Based Pumps
- Electric Pumps
- Diesel Pumps
- Dewatering
- Water Treatment

# PUMPS





# RAPTOR 4L LITE



## BATTERY DRIVEN SEWER AND WATER TRANSFER PUMP.

### RAPTOR 4L LITE PUMP SPECIFICATIONS

Specification	
Connection Size	4"
Max. Flow	32 L/s
Max. Pressure	21m
Impeller Type	Screw Impeller
Solids Handling	75mm
Canopy Type	Silent, non-stackable
Weight	639kg
Dimensions	1399 x 907 x 1076mm
Temperature	Max. 40°C
Driven-by	Li-ion Battery
Battery Running Time	10 Hours
Battery Charging Time	2 Hours
Power	5.5 kW
Nominal Voltage	48V (42V/58.8V) Integrated frequency converter
Pump Type	Dry claw vacuum pump
Air Handling Capacity	35 CFM
Max. Vacuum	9.0m
Electric Motor	1.3 kW

Note: Specifications are approximate.

Speed: ● 1700rpm ● 1600rpm ● 1500rpm

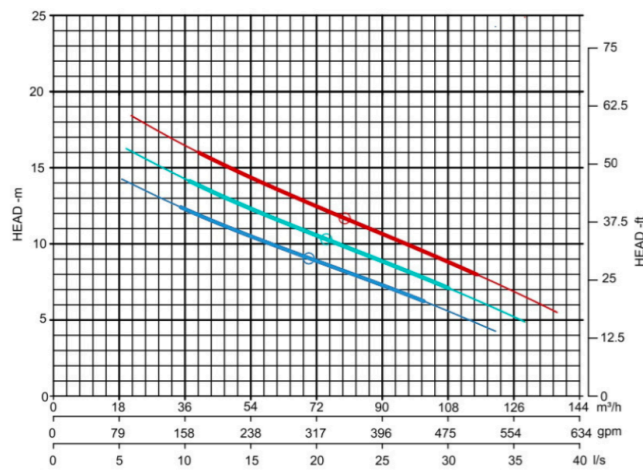

# RAPTOR 4D LITE



## DIESEL DRIVEN SEWER AND WATER TRANSFER PUMP.

### RAPTOR 4D LITE PUMP SPECIFICATIONS

Specification	
Connection Size	4"
Max. Flow	32 L/s
Max. Pressure	21m
Impeller Type	Screw Impeller
Solids Handling	75mm
Sound Level	53dB (at 10m)
Weight	639kg
Fuel Tank Capacity	50L
Dimensions	1399 x 907 x 1076mm
Temperature	Max. 40°C
Driven-by	Diesel
Model	Hatz 1D81
Emission Standard	Stage V / Tier 4F
Cylinders	1
Displacement Litres	0.667
Bore / Stroke mm	100 x 85
Max. Power	5.5kW @ 1700rpm
Variable Speed	1500 - 1700rpm
Combustion System	High Pressure Mechanical Direct Injection

Note: Specifications are approximate.

Speed: ● 1700rpm ● 1600rpm ● 1500rpm

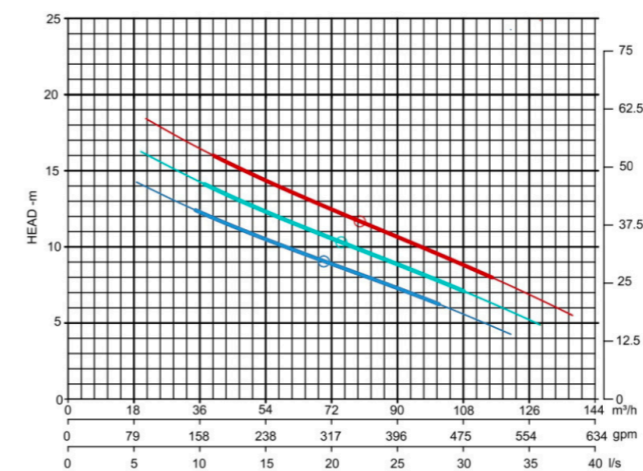

# RAPTOR 4D



Open/silent Canopy



Optional

## DIESEL DRIVEN SEWER AND WATER TRANSFER PUMP.

### OPTIONS:

- \*Raptor 4D Retro:  
Hatz 1D81, Retro Panel
- Raptor 4D  
Hatz 1D90E, AEONPUMP Software

### RAPTOR 4D PUMP SPECIFICATIONS

Specification	
Connection Size	4"
Max. Flow	46 L/s
Max. Pressure	21m
Impeller Type	Screw Impeller
Solids Handling	75mm
Sound Level	54dB (at 10m)
Weight	880kg
Fuel Tank Capacity	200L
Dimensions	1634 x 990 x 1482mm
Temperature	Max. 40°C
Driven-by	Diesel
Model	Hatz 1D90E / Hatz 1D81*
Emission Standard	Stage V / Tier 4F
Cylinders	1
Displacement Litres	0.722 / 0.667*
Bore / Stroke mm	104 x 85 / 100 x 85*
Max. Power	6.5kW @ 1700rpm
Variable Speed	1500- 1700rpm
Combustion System	High Pressure Mechanical Direct Injection

Note: Specifications are approximate.

Speed: ● 1700rpm ● 1600rpm ● 1500rpm

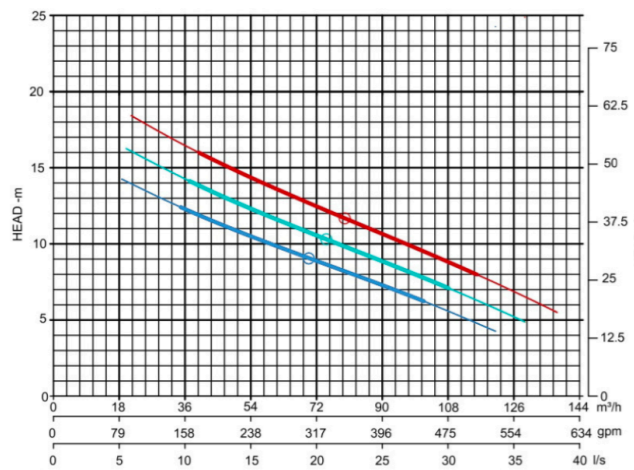

# RAPTOR 6D LITE



## DIESEL DRIVEN SEWER AND WATER TRANSFER PUMP.

### RAPTOR 6D LIGHT PUMP SPECIFICATIONS

Specification	
Connection Size	6"
Max. Flow	119 L/s
Max. Pressure	33m
Impeller Type	Screw Impeller
Solids Handling	100mm
Canopy	Silent, non stackable
Weight	830kg
Fuel Tank Capacity	150L
Dimensions	2015 x 1033 x 1254mm
Temperature	Max. 40°C
Driven-by	Diesel
Model	Hatz 3H50T
Emission Standard	Stage V / Tier 4F
Cylinders	3
Displacement Litres	1.464
Bore / Stroke mm	84 x 88
Max. Power	18.4kW @ 1600rpm
Variable Speed	1500- 1600rpm
Combustion System	Direct Injection with Bosch off-highway common-rail

Note: Specifications are approximate.

Speed: ● 1600rpm ● 1500rpm

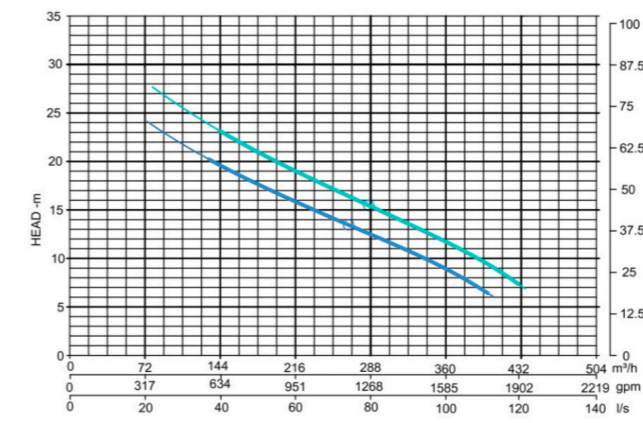

# RAPTOR 6D

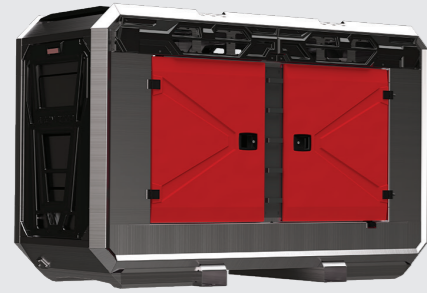

Open/silent Canopy

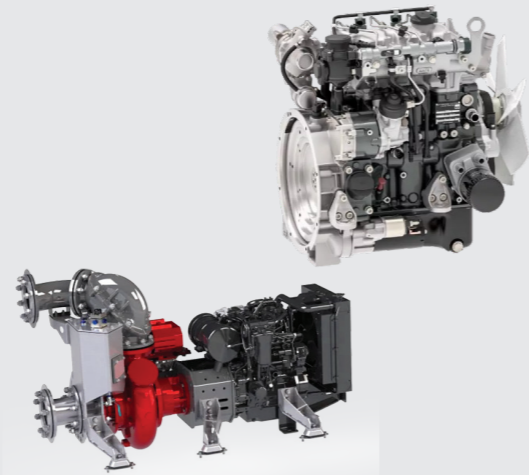

## DIESEL DRIVEN SEWER AND WATER TRANSFER PUMP.

### RAPTOR 6D PUMP SPECIFICATIONS

Specification	
Connection Size	6"
Max. Flow	119 L/s
Max. Pressure	33m
Impeller Type	Screw Impeller
Solids Handling	100mm
Sound Level	62dB (at 10m)
Weight	1350kg
Fuel Tank Capacity	270L
Dimensions	2299 x 1100 x 1601mm
Temperature	Max. 40°C
Driven-by	Diesel
Model	Hatz 4H50N
Emission Standard	Stage V / Tier 4F
Cylinders	3
Displacement Litres	1.952
Bore / Stroke mm	84 x 88
Max. Power	18.4kW @ 1800rpm
Variable Speed	1500- 1800rpm
Combustion System	Direct Injection with Bosch off-highway common-rail

Note: Specifications are approximate.

Speed: ● 1600rpm ● 1500rpm

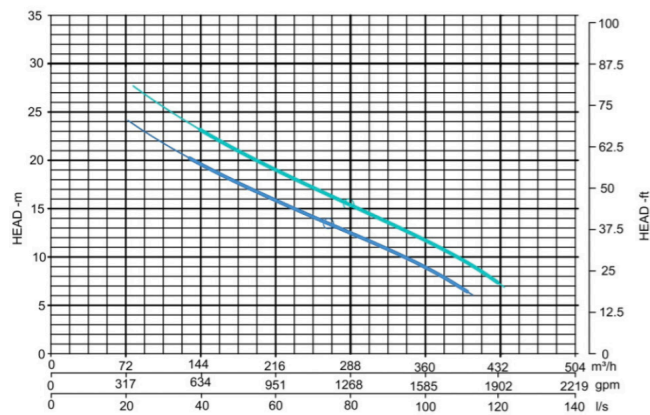

# RAPTOR 6D HEAVY



Open/silent Canopy

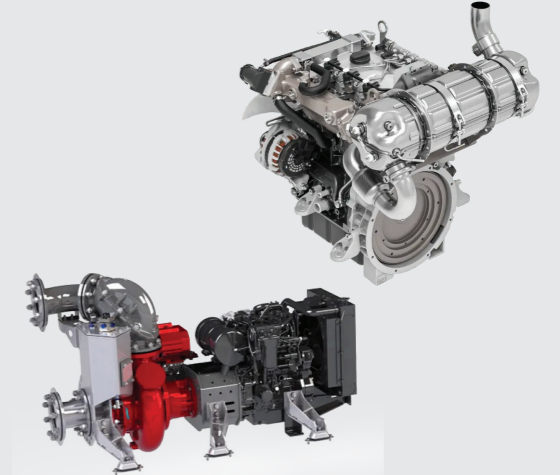

## DIESEL DRIVEN SEWER AND WATER TRANSFER PUMP.

### RAPTOR 6D HEAVY PUMP SPECIFICATIONS

Specification	
Connection Size	6"
Max. Flow	139 L/s
Max. Pressure	46m
Impeller Type	Screw Impeller
Solids Handling	100mm
Canopy	64dB (at 10m)
Weight	1450kg
Fuel Tank Capacity	270L
Dimensions	2299 x 1100 x 1601mm
Temperature	Max. 40°C
Driven-by	Diesel
Model	Hatz 3H50TICD / Hatz 3H50TIC
Emission Standard	Stage V / Tier 4F
Cylinders	3
Displacement Litres	1.46
Bore / Stroke mm	84 x 88
Max. Power	27kW @ 1900rpm
Variable Speed	1300- 1900rpm
Combustion System	High-pressure common rail direct injection

Note: Specifications are approximate.

Speed: ● 1900rpm ● 1800rpm

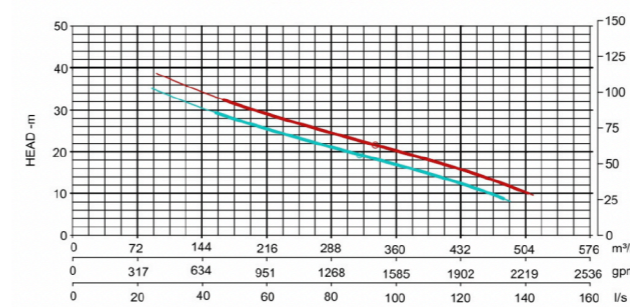



# RAPTOR 8D



Open/silent Canopy

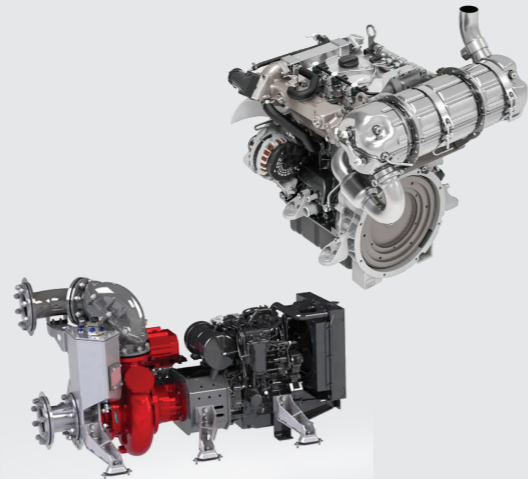

## DIESEL DRIVEN SEWER AND WATER TRANSFER PUMP.

### RAPTOR 8D PUMP SPECIFICATIONS

Specification	
Connection Size	8"
Max. Flow	166 L/s
Max. Pressure	44m
Impeller Type	Screw Impeller
Solids Handling	115mm
Sound Level	73dB (at 10m)
Weight	1950kg
Fuel Tank Capacity	270L
Dimensions	2299 x 1100 x 1601mm
Temperature	Max. 40°C
Driven-by	Diesel
Model	Hatz 3H50TICD / Hatz 3H50TIC
Emission Standard	Stage V / Tier 4F
Cylinders	3
Displacement Litres	1.464
Bore / Stroke mm	84 x 88
Max. Power	28kW @ 1700rpm
Variable Speed	1500 - 3000rpm
Combustion System	High-pressure common rail direct injection

Note: Specifications are approximate.

Speed: ● 1700rpm ● 1600rpm ● 1500rpm

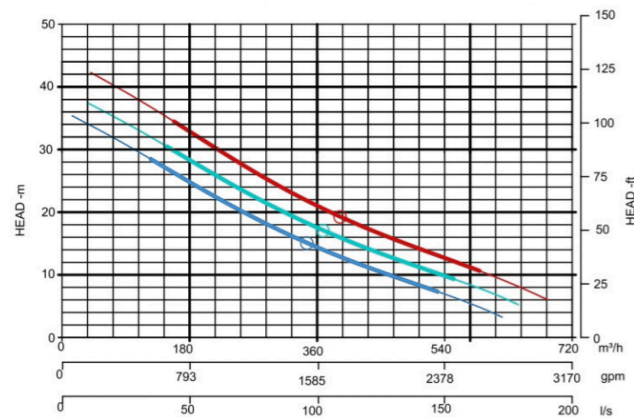

# RAPTOR 8D HEAVY

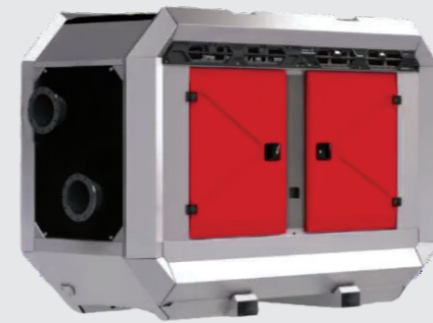

Open/silent Canopy

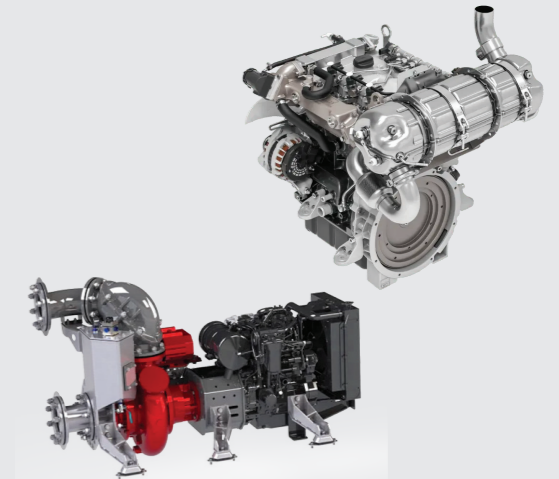

## DIESEL DRIVEN SEWER AND WATER TRANSFER PUMP.

### RAPTOR 8D HEAVY PUMP SPECIFICATIONS

Specification	
Connection Size	8"
Max. Flow	200 L/s
Max. Pressure	52m
Impeller Type	Screw Impeller
Solids Handling	115mm
Canopy	76dB (at 10m)
Weight	1950kg
Fuel Tank Capacity	400L
Dimensions	2700 x 1150 x 1820 mm
Temperature	Max. 40°C
Driven-by	Diesel
Model	Hatz 4H50TICD / Hatz 4H50TIC
Emission Standard	Stage V / Tier 4F
Cylinders	4
Displacement Litres	1.952
Aspiration	Turbocharged air cooling
Bore / Stroke mm	84 x 88
Max. Power	45kW @ 1700rpm
Variable Speed	1500 - 3000rpm
Combustion System	Direct Injection
Exhaust After Treatment	DOC, DPF

Note: Specifications are approximate.

Speed: ● 1700rpm ● 1600rpm ● 1500rpm

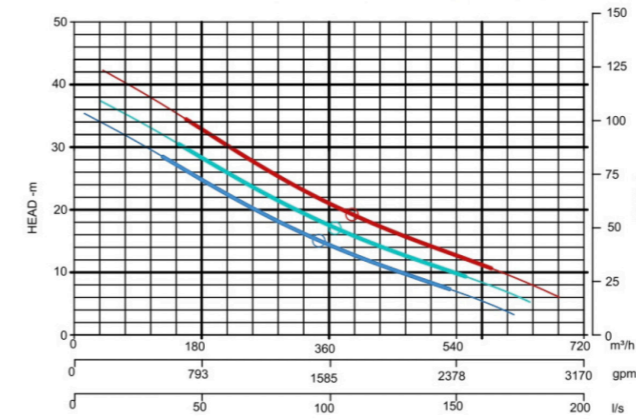



# RAPTOR 12D

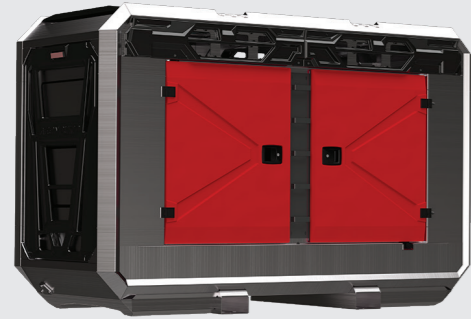

Open/silent Canopy

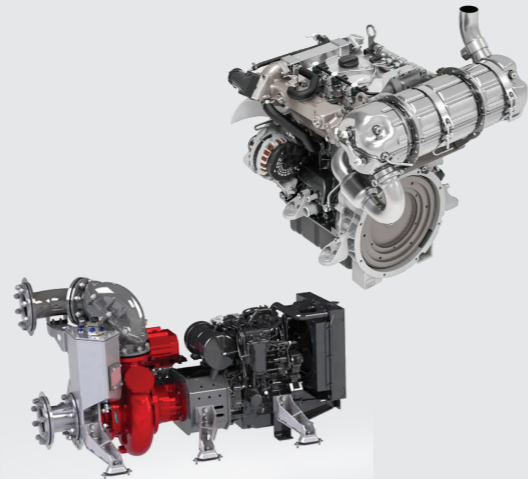

## DIESEL DRIVEN SEWER AND WATER TRANSFER PUMP.

### RAPTOR 12D PUMP SPECIFICATIONS

Specification	
Connection Size	12"
Max. Flow	290 L/s
Max. Pressure	35m
Impeller Type	Screw Impeller
Solids Handling	120mm
Canopy	72dB (at 10m)
Weight	3200kg
Fuel Tank Capacity	400L
Dimensions	2700 x 1150 x 1820 mm
Temperature	Max. 40°C
Driven-by	Diesel
Model	Hatz 4H50TICD / Hatz 4H50TIC
Emission Standard	Stage V / Tier 4F
Cylinders	4
Displacement Litres	1.952
Aspiration	Turbocharged air cooling
Bore / Stroke mm	84 x 88
Max. Power	45kW @ 1700rpm
Variable Speed	1500- 3000rpm
Combustion System	Direct Injection
Exhaust After Treatment	DOC, DPF

Note: Specifications are approximate.

Speed: ● 1700rpm ● 1600rpm ● 1500rpm

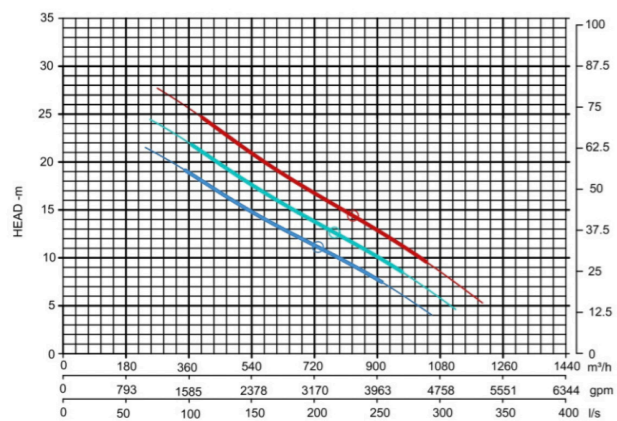

# RAPTOR 12D HEAVY

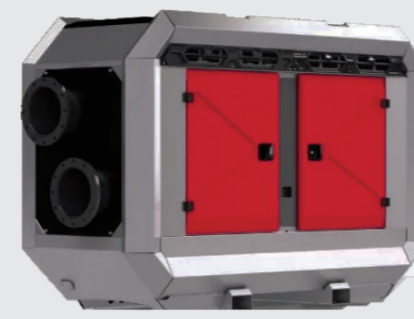

Open/silent Canopy

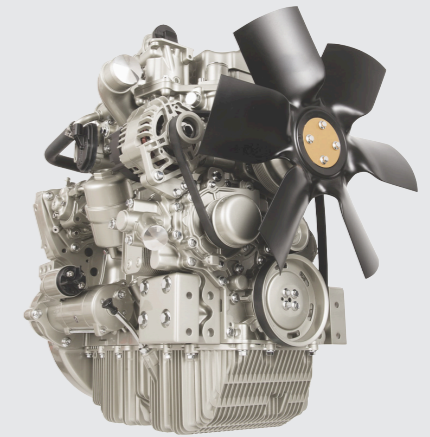

## DIESEL DRIVEN SEWER AND WATER TRANSFER PUMP.

### RAPTOR 12D HEAVY PUMP SPECIFICATIONS

Specification	
Connection Size	12"
Max. Flow	1260 m3/h
Max. Pressure	45m
Impeller Type	Screw Impeller
Solids Handling	120mm
Canopy	75dB (at 10m)
Weight	3300kg
Fuel Tank Capacity	400L
Dimensions	2700 x 1150 x 1820 mm
Temperature	Max. 40°C
Driven-by	Diesel
Model	Perkins 904J-E36TA
Emission Standard	Stage V
Cylinders	4
Displacement Litres	3.6
Aspiration	Turbocharged after-cooled
Bore / Stroke mm	98 x 120
Max. Power	65kW @ 1700rpm
Variable Speed	1000- 1800rpm
Combustion System	Direct Injection
Exhaust After Treatment	DOC, DPF

Note: Specifications are approximate.

Speed: ● 1700rpm ● 1600rpm ● 1500rpm

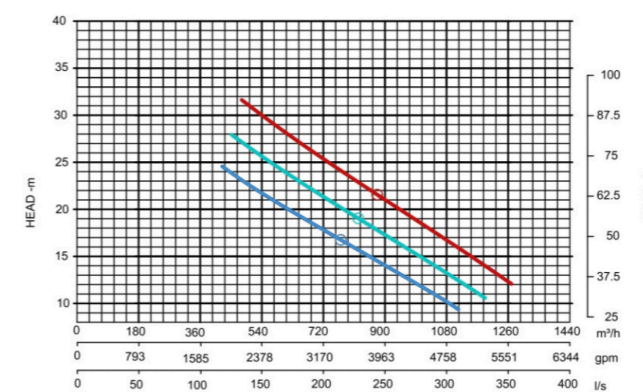



# KRAKEN 4D & 6D



## DIESEL DRIVEN WELLPOINT DEWATERING PUMP.

# KRAKEN 4D & 6D

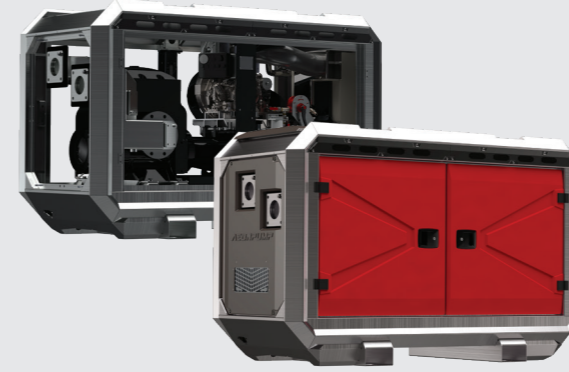

Silent Canopy



### KRAKEN 4D PUMP SPECIFICATIONS

Specification	
Connection Size	4"
Max. Flow	26 L/s
Max. Pressure	20m
Max. Suction	9.6m
Pump Type	Piston Pump
Sound Level	48dB (at 10m)
Weight	1500kg
Fuel Tank Capacity	200L
Fuel Consumption	1 l/h
Dimensions	2300 x 1000 x 1400 mm
Driven-by	Diesel
Model	Hatz 1D81
Emission Standard	Stage V
Cylinders	1
Displacement Litres	0.667
Bore / Stroke mm	100 x 85
Max. Power	5.5kW @ 1500rpm
Variable Speed	1500- 1700rpm
Combustion System	High Pressure Mechanical Direct Injection

Note: Specifications are approximate.

### KRAKEN 6D PUMP SPECIFICATIONS

Specification	
Connection Size	6"
Max. Flow	26 L/s
Max. Pressure	20m
Max. Suction	9.6m
Pump Type	Piston Pump
Sound Level	48dB (at 10m)
Weight	1500kg
Fuel Tank Capacity	200L
Fuel Consumption	1 l/h
Dimensions	2300 x 1000 x 1400 mm
Driven-by	Diesel
Model	Hatz 1D90E
Emission Standard	Stage V
Cylinders	1
Displacement Litres	0.722
Bore / Stroke mm	104 x 85
Max. Power	5.5kW @ 1500rpm
Variable Speed	1500- 1700rpm
Combustion System	High Pressure Mechanical Direct Injection

Note: Specifications are approximate.



# RAPTOR 4E

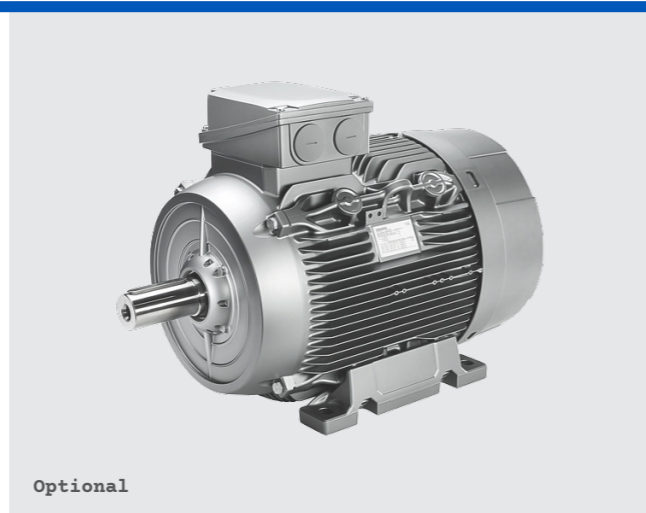

## ELECTRICALLY DRIVEN SEWER AND WATER TRANSFER PUMP.

**OPTIONS:**

- Raptor 4E Retro: Star Delta, Retro Panel
- Raptor 4E: Frequency converter, AEONPUMP Software

### RAPTOR 4E PUMP SPECIFICATIONS

Specification	
Connection Size	4"
Max. Flow	40 L/s
Max. Pressure	15m
Impeller Type	Screw Impeller
Solids Handling	75mm
Canopy Type	Silent, Stackable
Weight	900kg
Dimensions	1634 x 990 x 1482mm
Temperature	Max. 40°C
Driven-by	Electricity
Power	5.5kW
Rated Voltage	400/690V 50Hz
Rotation Speed	1438rpm
Standard	EC Directive 2005/32
Pump Type	Dry claw vacuum pump
Air Handling Capacity	35 CFM
Max. Vacuum	9.0m
Electric Motor	1.3 kW

Note: Specifications are approximate.

Speed: ● 1438rpm

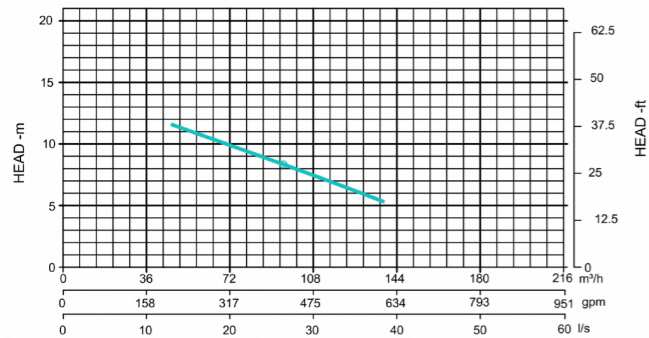

# RAPTOR 4E HEAVY

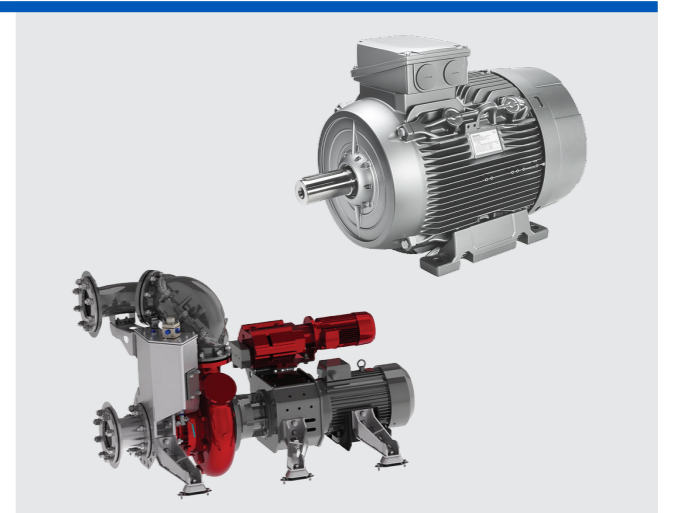

## ELECTRICALLY DRIVEN SEWER AND WATER TRANSFER PUMP.

### RAPTOR 4E HEAVY PUMP SPECIFICATIONS

Specification	
Connection Size	4"
Max. Flow	46 L/s
Max. Pressure	21m
Impeller Type	Screw Impeller
Solids Handling	75mm
Canopy Type	Silent, Stackable
Weight	900kg
Dimensions	1634 x 990 x 1482mm
Temperature	Max. 40°C
Driven-by	Electricity
Power	7.5kW
Rated Voltage	400/690V 50Hz
Rotation Speed	1700rpm
Standard	EC Directive 2005/32
Pump Type	Dry claw vacuum pump
Air Handling Capacity	35 CFM
Max. Vacuum	9.0m
Electric Motor	1.3 kW

Note: Specifications are approximate.

Speed: ● 1700rpm ● 1438rpm

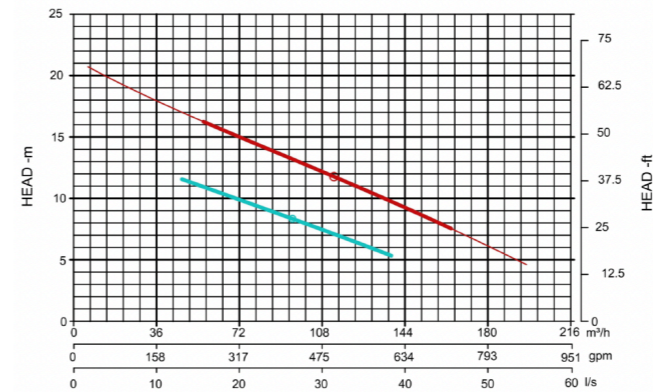

# RAPTOR 6E

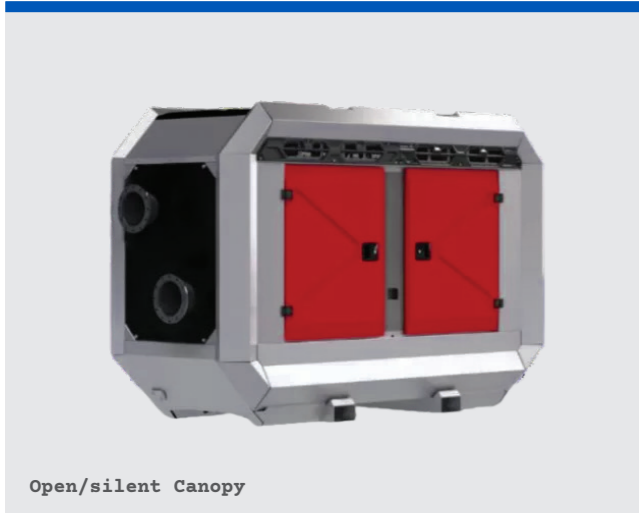

## ELECTRICALLY DRIVEN SEWER AND WATER TRANSFER PUMP.

**OPTIONS:**

- Raptor 6E Retro: Star Delta, Retro Panel
- Raptor 6E: Frequency converter, AEONPUMP Software

### RAPTOR 6E PUMP SPECIFICATIONS

Specification	
Connection Size	6"
Max. Flow	105 L/s
Max. Pressure	26m
Impeller Type	Screw Impeller
Solids Handling	100mm
Canopy Type	Silent, Stackable
Weight	1150kg
Dimensions	2299 x 1100 x 1601mm
Temperature	Max. 40°C
Driven-by	Electricity
Power	15kW
Rated Voltage	400/690V 50Hz
4-Pole	1474rpm
Pump Type	Dry claw vacuum pump
Air Handling Capacity	35 CFM
Max. Vacuum	9.0m
Electric Motor	1.3 kW

Note: Specifications are approximate.

Speed: ● 1474rpm

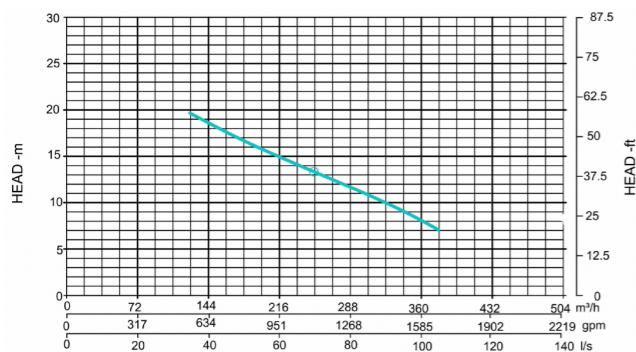

# RAPTOR 6E HEAVY

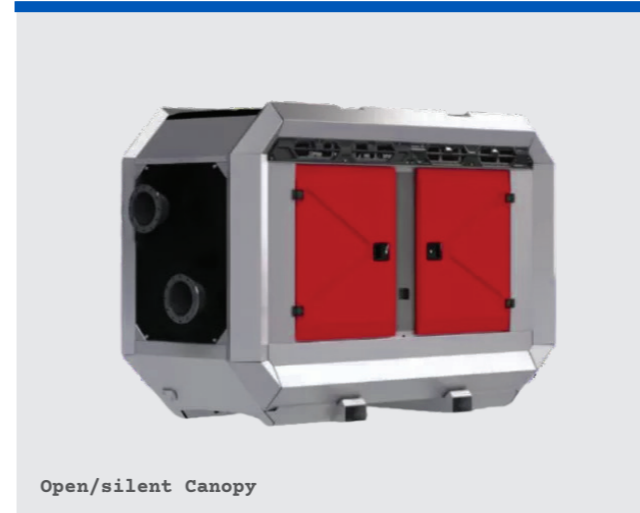

## ELECTRICALLY DRIVEN SEWER AND WATER TRANSFER PUMP.

### RAPTOR 6E HEAVY PUMP SPECIFICATIONS

Specification	
Connection Size	6"
Max. Flow	105 L/s
Max. Pressure	26m
Impeller Type	Screw Impeller
Solids Handling	100mm
Canopy Type	Silent, Stackable
Weight	1150kg
Dimensions	2299 x 1100 x 1601mm
Temperature	Max. 40°C
Driven-by	Electricity
Power	15kW
Rated Voltage	400/690V 50Hz
4-Pole	1474rpm
Pump Type	Dry claw vacuum pump
Air Handling Capacity	35 CFM
Max. Vacuum	9.0m
Electric Motor	1.3 kW

Note: Specifications are approximate.

Speed: ● 1700rpm ● 1474rpm

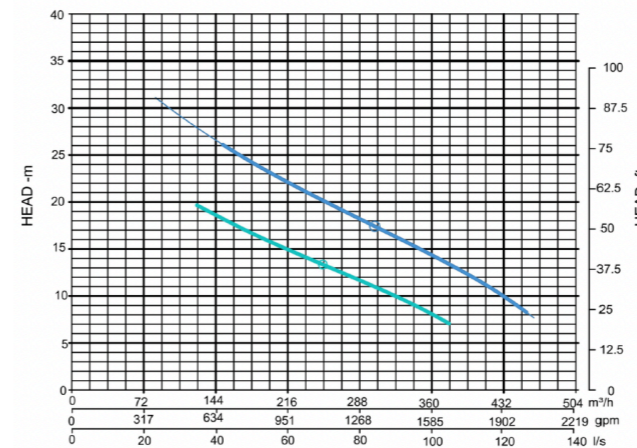



# RAPTOR 8E

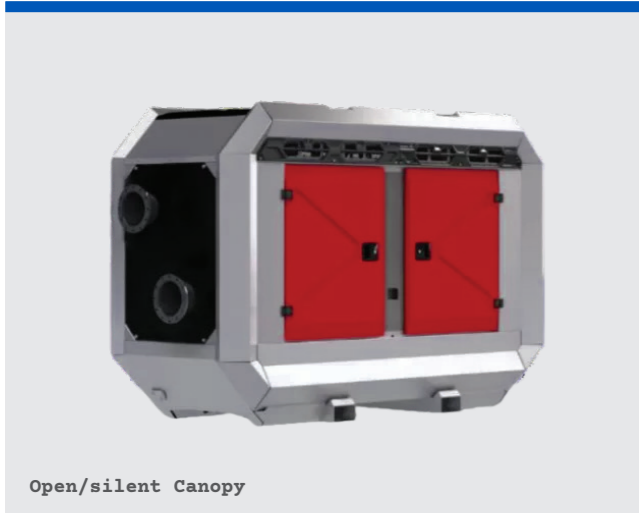

## ELECTRICALLY DRIVEN SEWER AND WATER TRANSFER PUMP.

**OPTIONS:**

- Raptor 8E Retro: Star Delta, Retro Panel
- Raptor 8E: Frequency converter, AEONPUMP Software

### RAPTOR 8E PUMP SPECIFICATIONS

Specification	
Connection Size	8"
Max. Flow	139 L/s
Max. Pressure	32m
Impeller Type	Screw Impeller
Solids Handling	115mm
Canopy Type	Silent, Stackable
Weight	1800kg
Dimensions	2299 x 1100 x 1601mm
Temperature	Max. 40°C
Driven-by	Electricity
Power	15kW
Rated Voltage	400/690V 50Hz
4-Pole	1474rpm
Pump Type	Dry claw vacuum pump
Air Handling Capacity	35 CFM
Max. Vacuum	9.0m
Electric Motor	1.3 kW

Note: Specifications are approximate.

Speed: ● 1470rpm

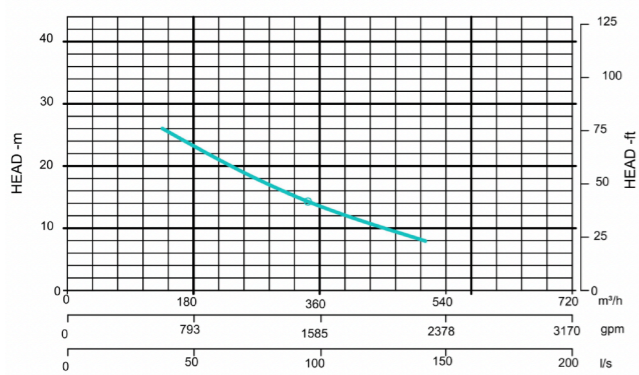

# RAPTOR 8E HEAVY

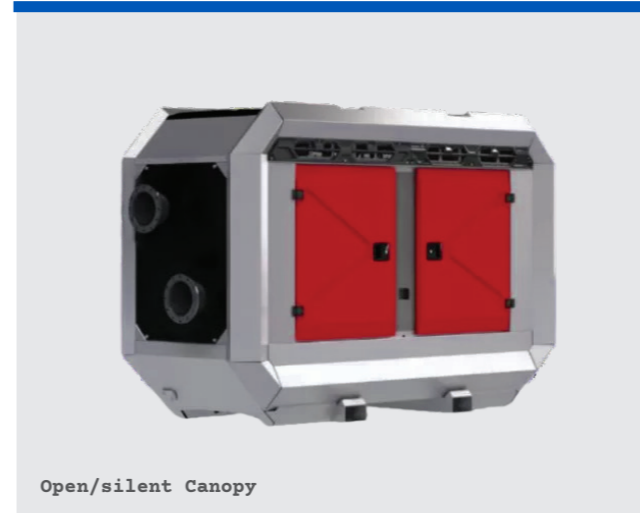

## ELECTRICALLY DRIVEN SEWER AND WATER TRANSFER PUMP.

### RAPTOR 8E HEAVY PUMP SPECIFICATIONS

Specification	
Connection Size	8"
Max. Flow	175 L/s
Max. Pressure	40m
Impeller Type	Screw Impeller
Solids Handling	115mm
Canopy Type	Silent, Stackable
Weight	1900kg
Dimensions	2700 x 1150 x 1820mm
Temperature	Max. 40°C
Driven-by	Electricity
Power	30kW
Rated Voltage	400/690V 50Hz
4-Pole	1483rpm
Pump Type	Dry claw vacuum pump
Air Handling Capacity	35 CFM
Max. Vacuum	9.0m
Electric Motor	1.3 kW

Note: Specifications are approximate.

Speed: ● 1483rpm

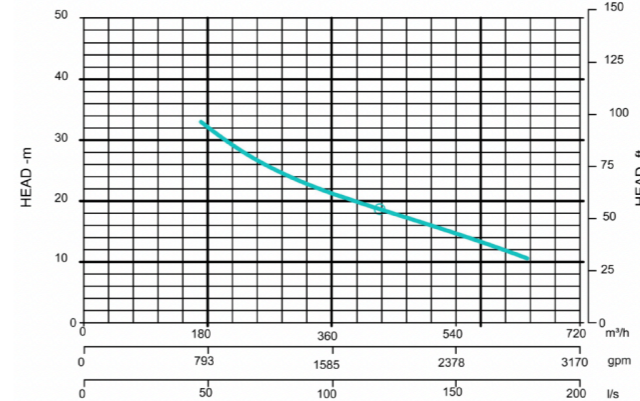



# RAPTOR 12E

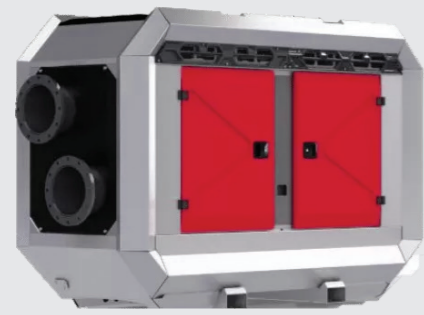

Open/silent Canopy

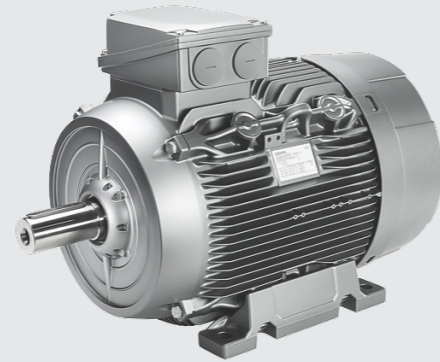

## ELECTRICALLY DRIVEN SEWER AND WATER TRANSFER PUMP.

### OPTIONS:

- Raptor 12E Retro: Star Delta, Retro Panel
- Raptor 12E: Frequency converter, AEONPUMP Software

### RAPTOR 12E PUMP SPECIFICATIONS

Specification	
Connection Size	12"
Max. Flow	250 L/s
Max. Pressure	26m
Impeller Type	Screw Impeller
Solids Handling	120mm
Canopy Type	Silent, Stackable
Weight	2100kg
Dimensions	2299 x 1100 x 1601mm
Temperature	Max. 40°C
Driven-by	Electricity
Power	30kW
Rated Voltage	400/690V 50Hz
4-Pole	1480rpm
Pump Type	Dry claw vacuum pump
Air Handling Capacity	35 CFM
Max. Vacuum	9.0m
Electric Motor	1.3 kW

Note: Specifications are approximate.

Speed: ● 1480rpm

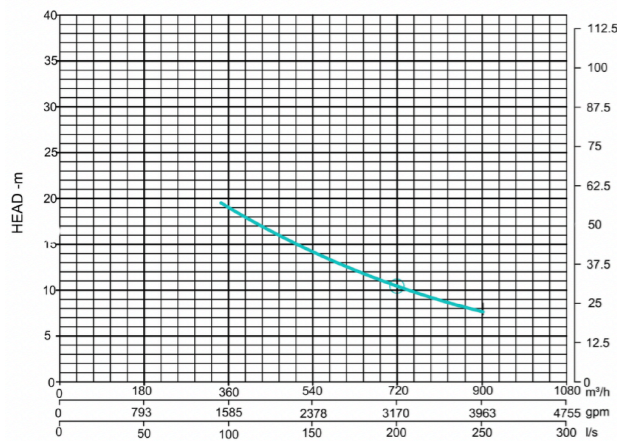

# RAPTOR 12E HEAVY

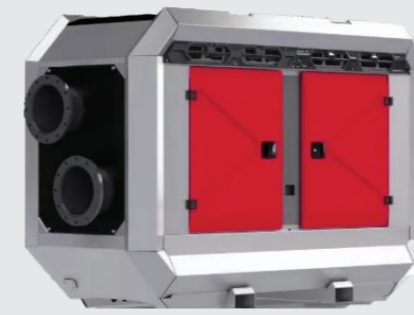

Open/silent Canopy

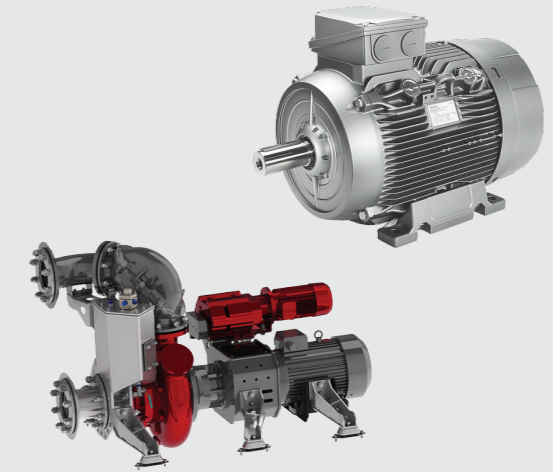

## ELECTRICALLY DRIVEN SEWER AND WATER TRANSFER PUMP.

### RAPTOR 12E HEAVY PUMP SPECIFICATIONS

Specification	
Connection Size	12"
Max. Flow	305 L/s
Max. Pressure	35m
Impeller Type	Screw Impeller
Solids Handling	120mm
Canopy Type	Silent, Stackable
Weight	2400kg
Dimensions	2700 x 1150 x 1820mm
Temperature	Max. 40°C
Driven-by	Electricity
Power	45kW
Rated Voltage	400/690V 50Hz
4-Pole	1483rpm
Pump Type	Dry claw vacuum pump
Air Handling Capacity	35 CFM
Max. Vacuum	9.0m
Electric Motor	1.3 kW

Note: Specifications are approximate.

Speed: ● 1485rpm

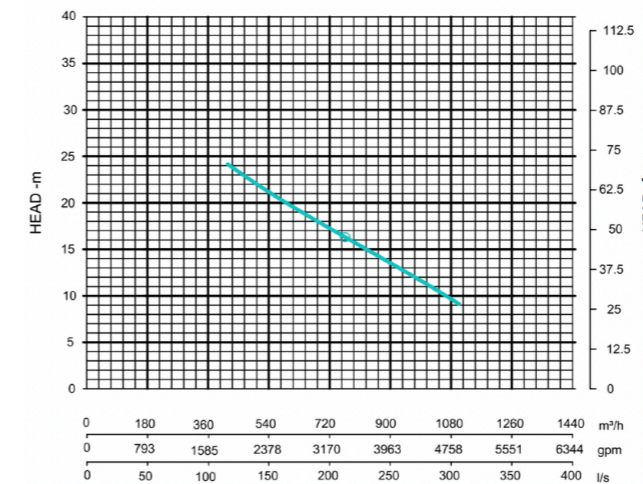



# KRAKEN 4E

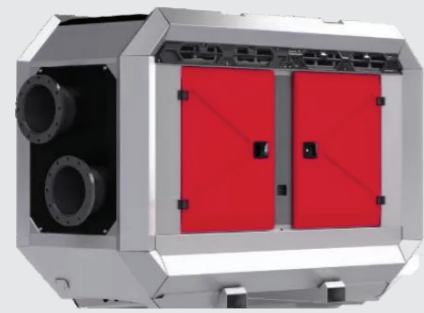

Open Canopy

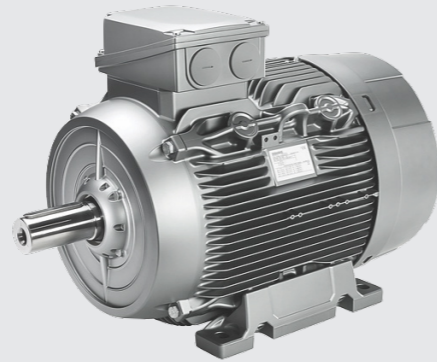

## ELECTRICALLY DRIVEN SEWER AND WATER TRANSFER PUMP.

### KRAKEN 4E PUMP SPECIFICATIONS

Specification	
Connection Size	4"
Max. Flow	26 L/s
Max. Pressure	20m
Max. Suction	9.6m
Pump Type	Piston Pump
Weight	1000kg
Dimensions	2000 x 1000 x 1290mm
Driven-by	Electricity
Power	5.5kW
Rated Voltage	400/690V 50Hz
4-Pole	1475rpm
Pump Type	Dry claw vacuum pump
Air Handling Capacity	35 CFM
Max. Vacuum	9.0m
Electric Motor	1.3 kW

Note: Specifications are approximate.

# PUMP SPECIFICATIONS

## ALL PRODUCT SPECIFICATIONS

Pump Model	Max Flow	Head	Solids	Weight	Power
RAPTOR 4L LITE	32 L/s	21 m	75 mm	650 kg	5.5 kW
RAPTOR 4D LITE	32 L/s	21 m	75 mm	550 kg	5.5 kW
RAPTOR 4D	46 L/s	21 m	75 mm	880 kg	6.5 kW
RAPTOR 6D LITE	119 L/s	33m	100 mm	830 kg	18.4 kW
RAPTOR 6D	119 L/s	33m	100 mm	1350 kg	18.4 kW
RAPTOR 6D HEAVY	139 L/s	46m	100 mm	1450 kg	27 kW
RAPTOR 8D	166 L/s	44m	115 mm	1950 kg	28 kW
RAPTOR 8D HEAVY	200 L/s	52m	115 mm	1950 kg	45 kW
RAPTOR 12D	200 L/s	35m	120 mm	3200 kg	45 kW
RAPTOR 12D HEAVY	350 L/s	45m	120 mm	3300 kg	65 kW
KRAKEN 4D	26 L/s	20m	-	1500 kg	5.5 kW
KRAKEN 6D	26 L/s	20m	-	1500 kg	5.5 kW
RAPTOR 4E	40 L/s	15m	75 mm	900 kg	5.5 kW
RAPTOR 4E HEAVY	45.8 L/s	21 m	75 mm	900 kg	7.5 kW
RAPTOR 6E	105 L/s	26 m	100 mm	1150 kg	15 kW
RAPTOR 6E HEAVY	125 L/s	38 m	100 mm	1150 kg	18.5 kW
RAPTOR 8E	139 L/s	32 m	115 mm	1800 kg	18.5 kW
RAPTOR 8E HEAVY	175 L/s	40 m	115 mm	1900 kg	30 kW
RAPTOR 12E	250 L/s	26m	120 mm	2100 kg	30 kW
RAPTOR 12E HEAVY	305 L/s	35m	120 mm	2100 kg	45 kW
KRAKEN 4E	26 L/s	20m	-	1000 kg	5.5 kW

\*Remote Telemetry available on all models Kraken & Raptor

